

T&B® Fittings

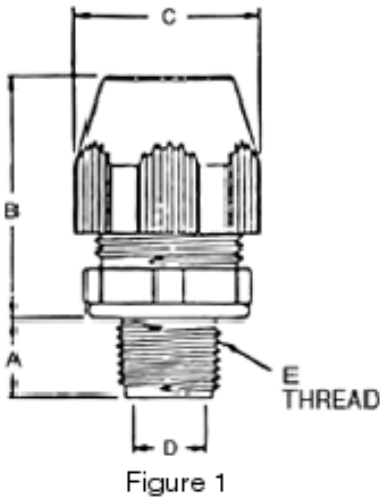

T&B Catalog Number: LT75P
UPC Number: 78621045066
Description: 3/4" Non-Metallic liquidtight Bullet® - Straight. For use with liquidtight non-metallic Type B conduit or liquidtight non-metallic tubing.
Status: Active



Features	
	Outside surface has friction reducing ridges.
	Inner surface teeth bite into conduit or tubing to enhance clamping and sealing action.
	Fitting ferrule designed to accept variations in conduit sizes and field conduit cuts.
	Smooth ferrule profile reduces friction to ensure a tight conduit-to-fitting seal.

Application	
	The Bullet® meets performance requirements when terminating Type B liquidtight non-metallic conduit or flexible non-metallic tubing to a box or enclosure with knockout opening or threaded hub.

General	
Trade Size (inches)	3/4
Material	Thermoplastic

Dimension Information	
Dimension A (inches)	0.582
Dimension B (inches)	1.757
Dimension C (inches)	1.740
Dimension D-Minimum Throat (inches)	0.740
E- NPT Thread (inches)	3/4-14
A (mm)	14.78
B (mm)	44.63
C (mm)	44.20
D (mm)	18.8

Packaging	
T&B Inner Pack	10
Package in Units	50
T&B Sold in UOM	Each
T&B Weight Per UOM	13.1 lbs. per 100

Application Support	
T&B Instruction Sheets	ta00998-tb2
Guide to Nonmetallic Conduit Applications	Available on Website
XTRAFLEX System Specifications	Available on Website

Notes	
*Note	Suitable for hazardous locations; Class I Div 2; Class II Div 1 & 2; Groups E, F, G; Class III per N.E.C.; Article 501-4, 502-4 and 503-3

Certifications	
RoHS Compliance	Yes

Certifications



File Nbr:
E 23018

XTRA FLEX® System —

Conduit, Tubing, Fittings for Non-Metallic Liquidtight Conduit

The BULLET® non-metallic liquidtight fitting — easy to use, built to take it!

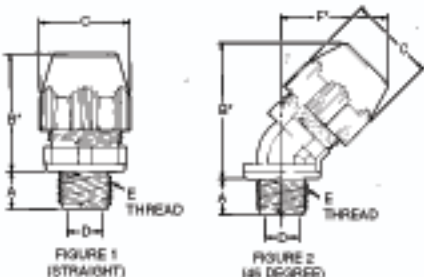
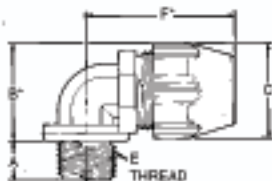

- Outside surface has friction-reducing ridges
- Inner surface teeth bite into conduit or tubing to enhance clamping and sealing action
- Fitting ferrule designed to accept variations in conduit sizes and field conduit cuts
- Smooth ferrule profile reduces friction to ensure a tight conduit-to-fitting seal
- Friction-reducing ridges and teeth provide a true double seal and high pullout resistance
- Elongated gland nut offers additional strain relief for 90° pull and easy hand grip
- Rugged low-profile nonmetallic body and gland construction provides space savings
- Captivated sealing O-Ring features predetermined compression to provide a reliable seal at enclosure
- Steel locknut firmly secures fitting to box or enclosure

FIGURE 1
(STRAIGHT)FIGURE 2
(145 DEGREE)FIGURE 3
(90 DEGREE)

Plastic Bullet® Liquidtight Fittings for T&B LTC Non-Metallic Liquidtight Conduit Type B and T&B EFC Flexible Tubing

This engineering breakthrough meets the demand for a tough, reusable, non-metallic liquidtight fitting for use with XTRA FLEX® Type B conduit or flexible tubing. The BULLET® non-metallic fitting provides a reliable liquidtight seal that combines high pullout resistance and ease of installation.

Engineered to meet your needs.

The BULLET® non-metallic fitting meets your performance requirements when terminating Type B liquidtight non-metallic conduit or flexible non-metallic tubing to a box or enclosure with knockout opening or threaded hub. Fittings meet the watertight requirements for NEMA Type 4 and Type 6 enclosures and conform to UL514B and CSA No. 22.2 #227.2 specifications.

Ease of installation.

Installations can be performed quickly and easily because BULLET® liquidtight fittings can be installed without disassembly. BULLET® nonmetallic fittings are resistant to numerous caustics and solvents.

The BULLET® fitting is economical because it can be used over and over again without sacrificing the quality of the original seal. When used with the XTRA FLEX® raceway system, you can meet most machine or industrial requirements where liquidtight protection is needed.

Corrosion resistant. Built to take it.

The BULLET® liquidtight fitting is manufactured from weather-resistant thermoplastic materials and is suitable for indoor or outdoor corrosive environments. The BULLET® fitting is resistant to detergents, cleaners, oils, sanitizers, paints, cutting fluids and wire pulling compounds — just about any liquid usually found in industrial, plant or marine environments. It also surpasses industry standards for cold impact and simulated hammer blows.



CAT. NO.	FIG.	TRADE SIZE (IN.)	A ±.015 (.040) (IN.) (MM)	*B ±.035 (0.90) (IN.) (MM)	C ±.015 (0.40) ACROSS CORNERS (IN.) (MM)	MIN. THROAT DIA. D (IN.) (MM)	E THREAD NPT (IN.)	F* (IN.) (MM) APPROX.
LT38P	1		.570	1.556 (40.51)	1.354	.417		—
LT438P	2	¾	(14.48)	2.012 (51.10)	(34.38)	(10.59)	¾-14	1.534 (38.95)
LT938P	3			1.380 (35.05)				1.880 (47.75)
LT50P	1		.570	1.636 (41.55)	1.448	.550		—
LT450P	2	¾	(14.48)	2.092 (53.14)	(36.78)	(13.97)	¾-14	1.590 (40.38)
LT950P	3			1.489 (37.82)				1.986 (50.44)
LT75P	1		.582	1.757 (44.63)	1.740	.740		—
LT475P	2	¾	(14.78)	2.452 (62.28)	(44.20)	(18.90)	¾-14	1.821 (46.25)
LT975P	3			1.790 (45.47)				2.212 (56.17)
LT100P	1		.726	1.923 (48.84)	2.068	.940		—
LT4100P	2	1	(18.44)	2.684 (68.17)	(52.53)	(23.88)	1-11/16	2.034 (51.66)
LT9100P	3			2.104 (53.44)				2.508 (63.70)
LT125P	1		.750	2.164 (54.97)	2.494	1.257		—
LT4125P	2	1½	(19.05)	3.264 (82.91)	(63.35)	(31.93)	1½-11/16	2.385 (60.58)
LT9125P	3			2.564 (65.13)				2.856 (72.54)
LT150P	1		.767	2.353 (59.77)	2.784	1.453		—
LT4150P	2	1½	(19.48)	3.606 (91.57)	(70.71)	(36.91)	1½-11/16	2.604 (66.14)
LT9150P	3			2.854 (72.49)				3.144 (79.86)
LT200P	1		.794	2.606 (66.17)	3.362	1.883		—
LT4200P	2	2	(20.17)	4.210 (106.93)	(85.38)	(47.83)	2-8	3.050 (77.47)
LT9200P	3			3.432 (87.17)				3.675 (93.34)

* After Assembly
UL File No. E-23016
CSA File No. 52391